

# INSTALLATION INSTRUCTIONS

DESCRIPTION: 12 Volt DC Power Outlet Kit  
PART NUMBER: 2PP-H21D0-V0  
MODEL: FJ-09



## ⚠ WARNING

Please read and understand these instructions completely before installation to avoid possible injury, or damage to the accessory or vehicle.

## NOTICE:

Installation of this kit requires a torque wrench as well as the Owner's Service Manual for the model. This installation should be performed by an authorized Yamaha dealer or a qualified mechanic.

## WARRANTY INFORMATION:

Yamaha Genuine Accessories are covered by a one-year limited warranty against defects in material or workmanship. Labor for replacement of defective components is not covered. See your Yamaha dealer for a copy of the warranty statement.

## DEALER OR INSTALLER:

These instructions contain important information for future reference and *must* be given to the customer.

## PARTS LIST:

No.	Part Number	Description	Qty
--	2PP-H21D0-V0	Power Outlet Kit	--
①	*	Mount Ring	1
②	*	12V Power Connector	1

\* Part supplied with kit only and not available separately.

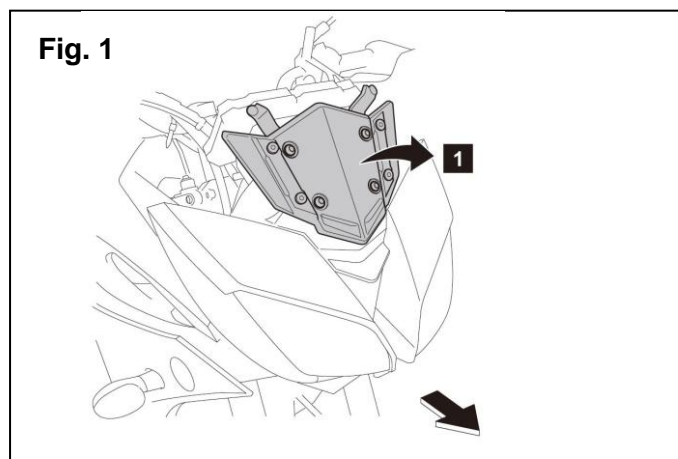
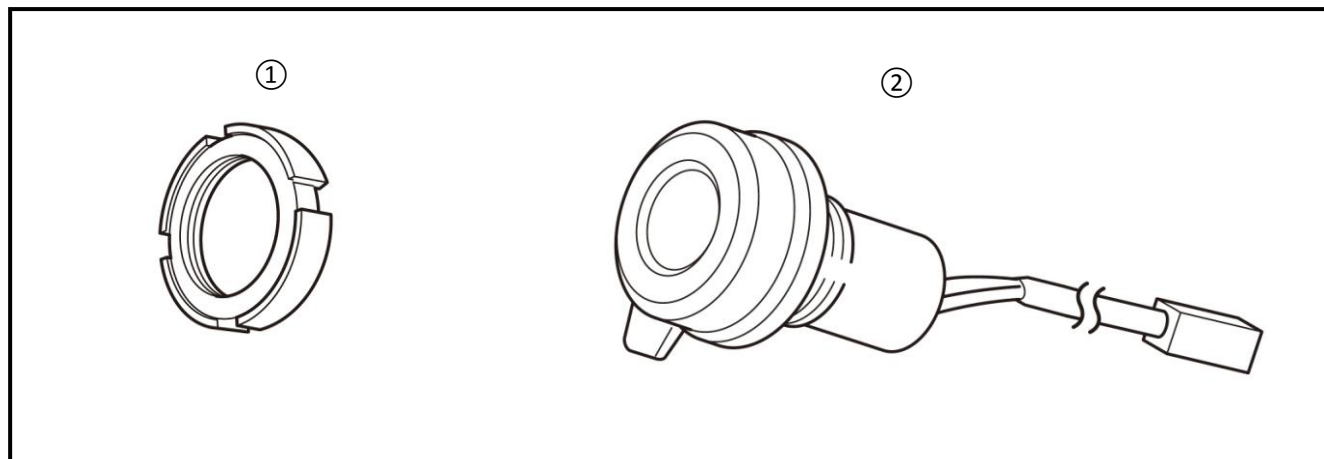

## PREPARATION:

1. Stand motorcycle on a secure and level surface.
2. Clean all mounting surfaces before beginning installation.

## INSTALLATION:

- 1 From the front, remove the four plastic screws that secure the windscreen to the windscreen mount. Then, remove the four bolts that hold the windscreen mount. Retain the screws, mount, and windscreen for re-installation (Fig. 1).

**Fig. 2**

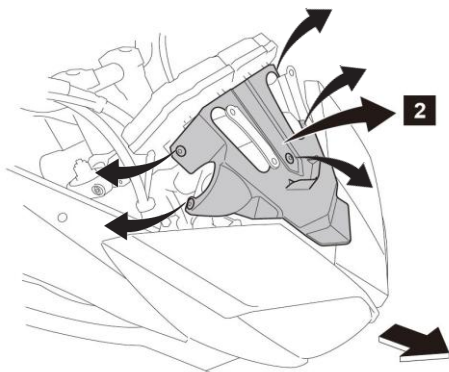

- 2 Remove the stock front dash cover. It is secured with five plastic push rivets. Four are around the edge of the cover, one is in the middle. Retain all hardware for re-installation (Fig. 2).

Working from behind the handlebars on the right side, remove the rubber cover from the mount location as shown in Fig. 3.

**Fig. 3**

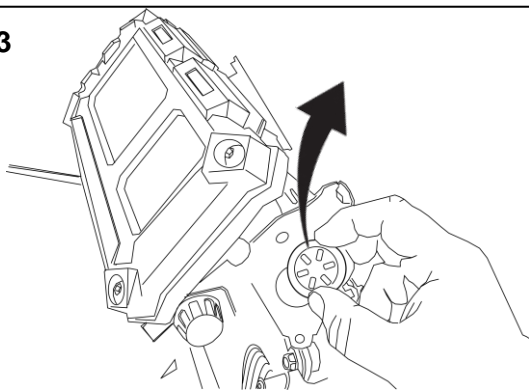

- 3 Press the 12V power connector ② through the circular mount (Fig. 3). Thread the Mount Ring ① to the threads on the 12V power connector ②. Tighten to 5N-m (0.5 kgf-m, 3.7 lbf-ft) (Fig. 4).

- 4 Working from the front, plug the connector from the 12v power connector ② into the open female connector as shown in Fig.5.

Use the stock hardware and components to reinstall the windscreen mount and windscreen. Refer to the Service Manual for details and torque settings.

**Fig. 4**

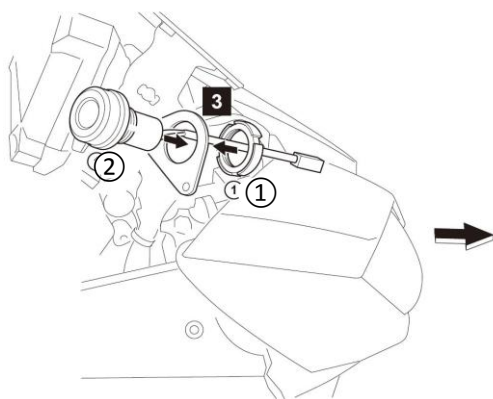

**MAINTENANCE:**

Periodically, check torque on all hardware. If loose hardware is found, re-torque to specification.

**CARE AND CLEANING:**

Use a clean soft cloth to clean the exterior of the outlet. Do not spray water into the dash area.

**CUSTOMER SERVICE:**

For further information see your Yamaha dealer.

**ESTIMATED TIME TO INSTALL: 0.7 HRS.**

**Fig. 5**

